

UNCONTROLLED IF PRINTED; CONTROLLED DOCUMENT LOCATED IN IQMS DOCUMENT CONTROL

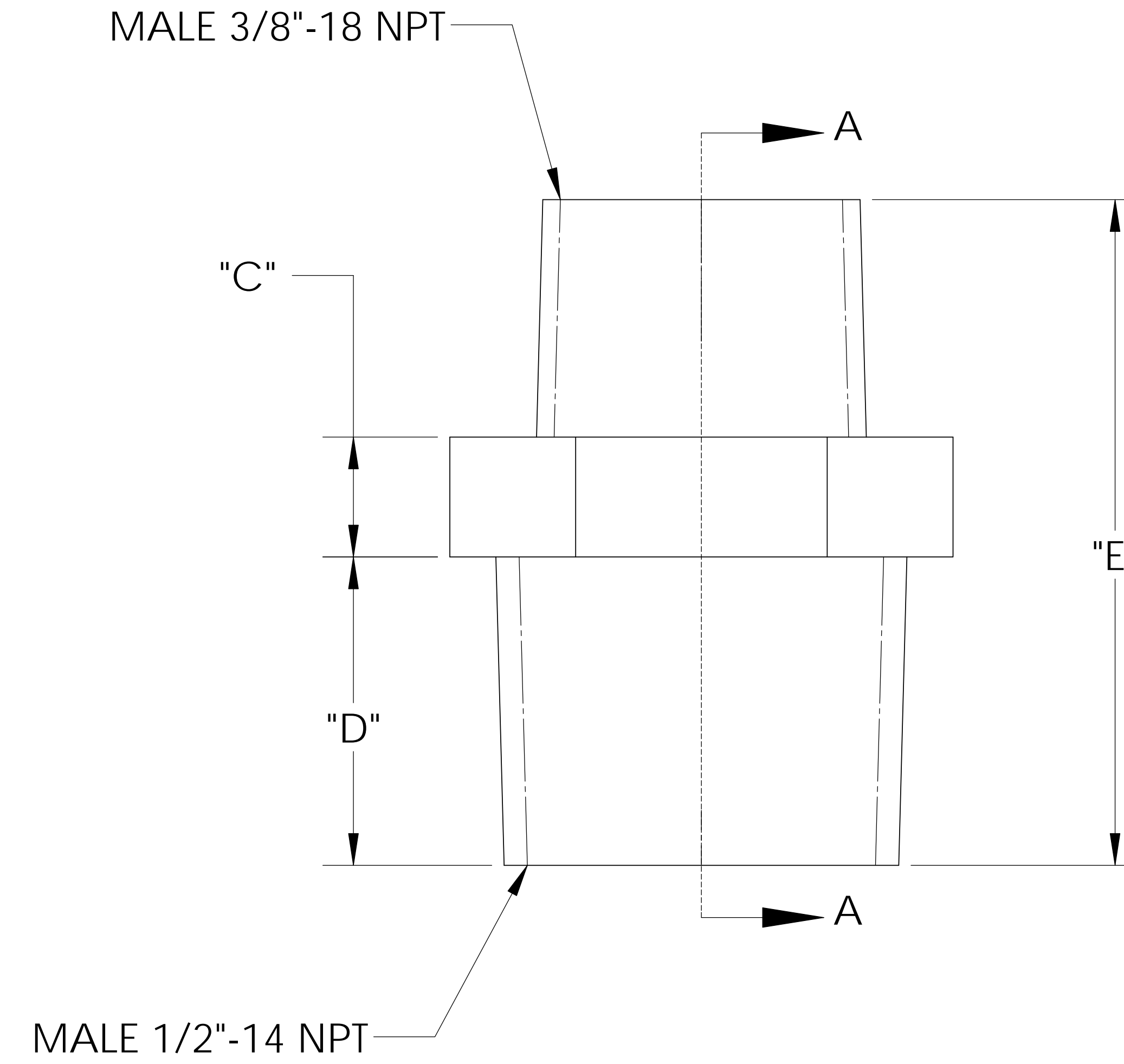
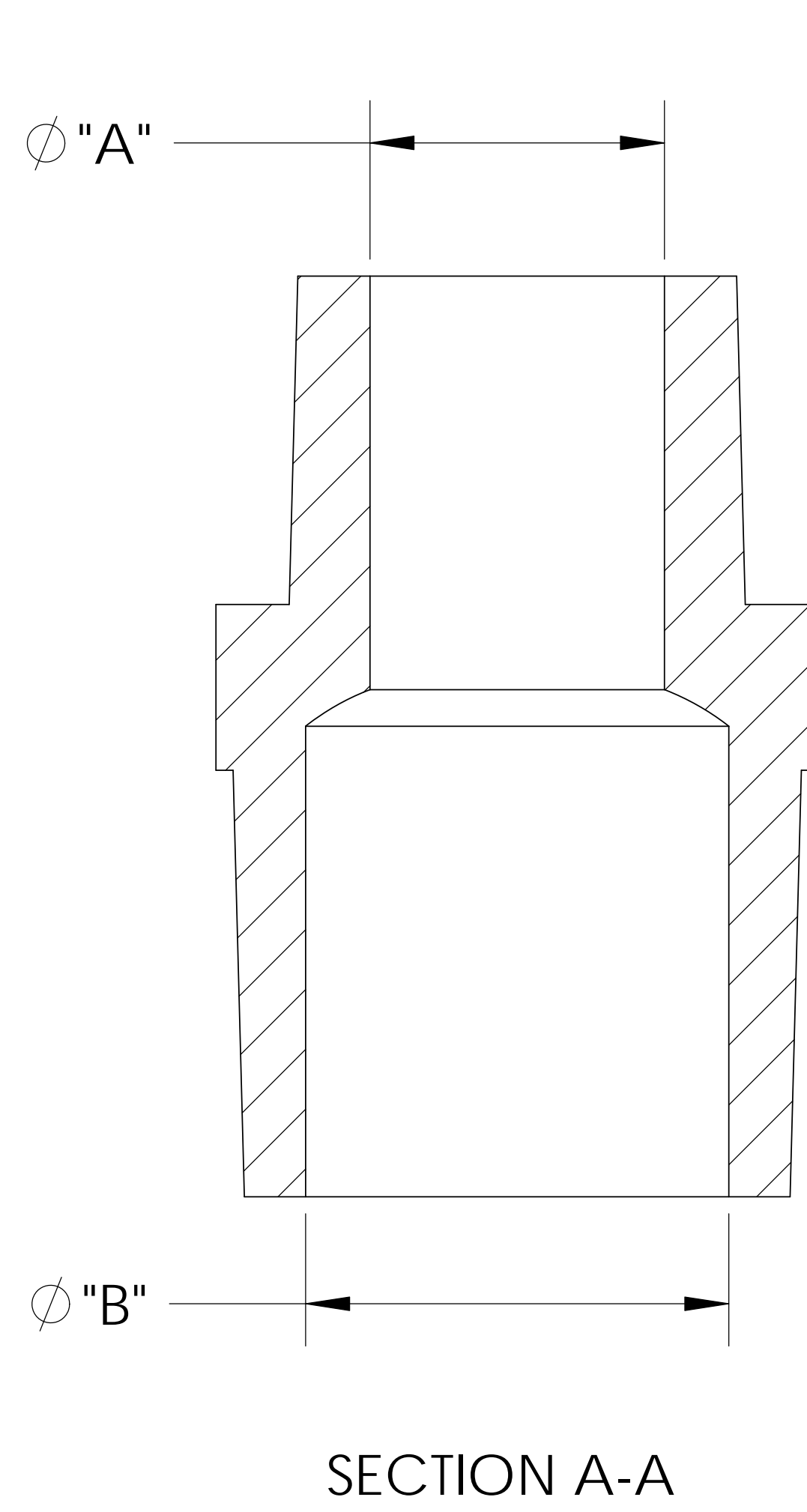
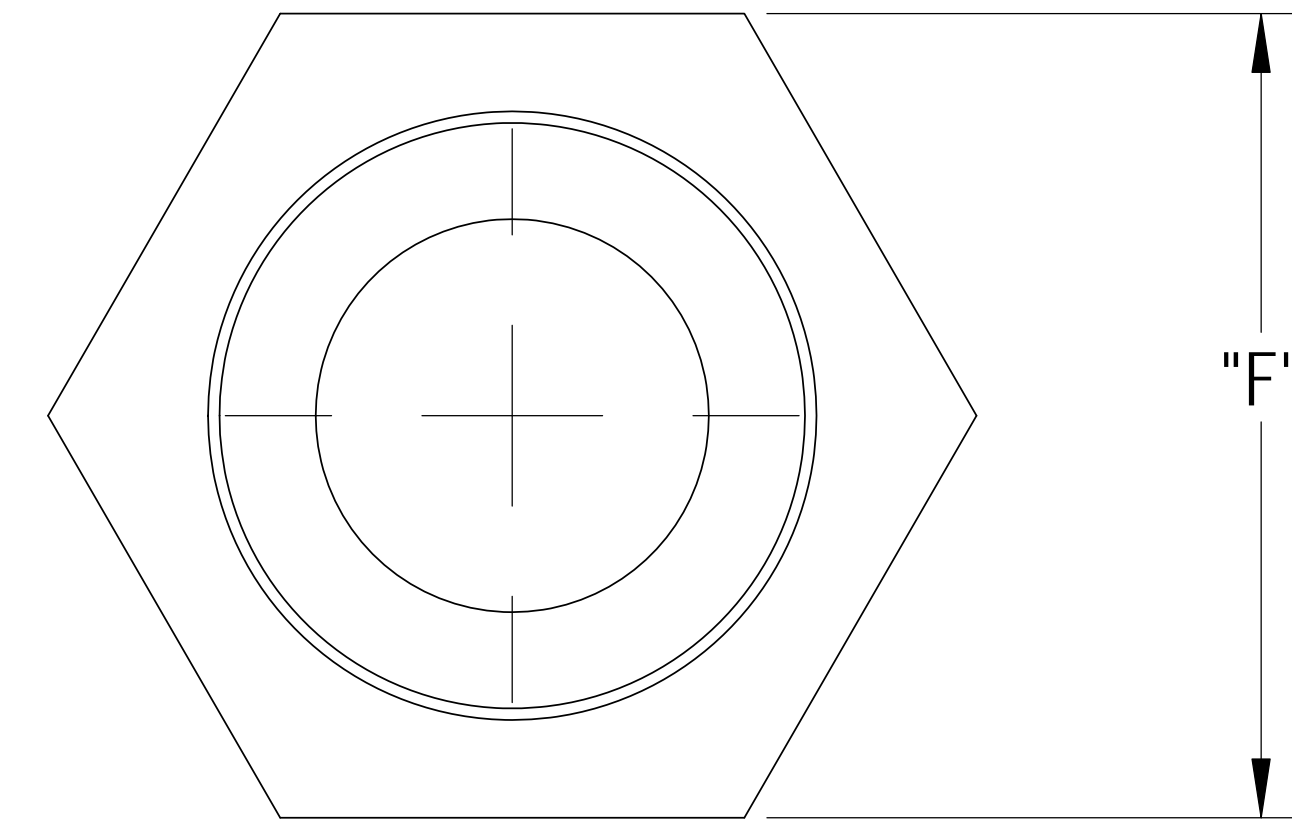
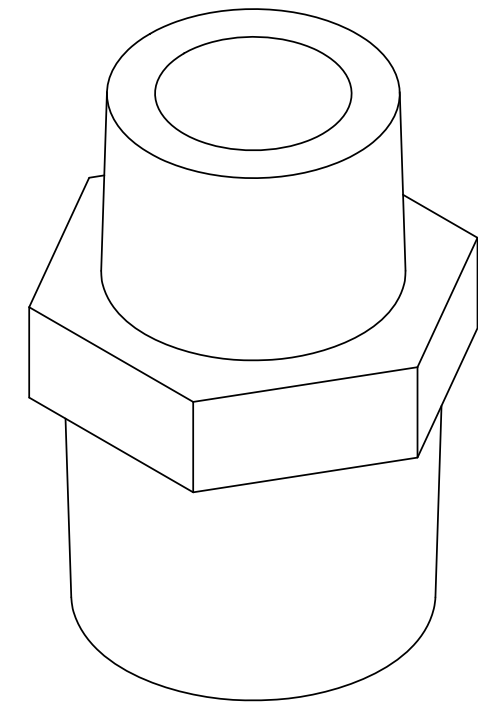

CATALOG NO.	DESCRIPTION	MATERIAL	DIM "A"	DIM "B"	DIM "C"	DIM "D"	DIM "E"	DIM "F"
TRN6086/PP	1/2" X 3/8" PP	POLYPROPYLENE	.430	.615	.255	.60	1.36	.88
TRN6086/P	1/2" X 3/8" P	POLYETHYLENE	.415	.600	.250	.60	1.33	.86
SHOWN TRN6086/N	1/2" X 3/8" N	NYLON	.435	.625	.245	.63	1.36	.89

NOTES:
 1) POLYPROPYLENE HAS COLOR OPTIONS:
 BLACK = TRN6086/PPB
 NATURAL = TRN6086/PPN

PROPRIETARY AND CONFIDENTIAL
 THE INFORMATION CONTAINED IN THIS DRAWING IS THE SOLE PROPERTY OF THOGUS PRODUCTS COMPANY. ANY REPRODUCTION IN PART OR AS A WHOLE WITHOUT THE WRITTEN PERMISSION OF THOGUS PRODUCTS COMPANY IS PROHIBITED.

REV	WRO#	DESCRIPTION
C	95.00126	CONVERTED TO 3D FORMAT
HISTORY		

UNLESS OTHERWISE SPECIFIED:
 DIMENSIONS ARE IN INCHES
 TOLERANCES:
 ANGULAR: ±0.5°
 XX = ± 0.1
 XXX = ± 0.05
 XXXX = ± 0.015
 REMOVE ALL SHARP EDGES AND BURRS
 BLEND ALL RADII TO 0.01IN
 INTERPRET GEOMETRIC TOLERANCING PER: ANSI Y 14.5 1994
 MATERIAL: PP, P, N
 FINISH: NA
 THIRD ANGLE PROJECTION:

NAME	DATE
DRAWN KDJ	12/29/10
CHECKED KDJ	12/29/10
ENG APPR.	XX/XX/XX
MFG APPR.	XX/XX/XX
Q.A.	XX/XX/XX

Thogus You think it, we can make it.
 33490 PIN OAK, AVON LAKE, OH 44012

TITLE: **1/2" NPT X 3/8" NPT REDUCER NIPPLE**

SIZE B	DWG. NO. TRN6086	REV C
SCALE: 2:1	MASS:	SHEET 1 OF 1

DO NOT SCALE DRAWING